

HOW TO ORDER

ESWKE	-G	04	-C2	-200	-ET	-D24	-K31	-A1
Series	Mounting Style	Nominal Size	Spool Type	Nominal Flow	Option ET	Power Supply	Connector	Command Value
Proportional directional valve, Pilot operated, close loop, with integrated electronics	G:Subplated Mounted	04: 16mm	①	200:180L/min	②	D24:DC24V	No code: amplifier connector K31:without	A1: ±10V F1: 4-20mA

① List of Spool Configurations

Application	Spool Type	Symbols	Application	Spool Type	Symbols
4-way, 3-position	C2 C21		4-way, 2-position		
	C40 C41				

Remarks: spool type C21, C41, rated flow ratio of P-A and B-T is 2:1, P-B and A-T is 1:2

② Option ET

Pilot Type		Drain Type	
E	No code	T	No code
External Pilot	Standard Internal Pilot Type	External Drain	Standard Internal Drain Type



Technical Data

Nominal Size	G04(16mm)
Installation Position	any, preferably horizontal
Storage temperature range	-15 to 80°C
Ambient temperature range	-15 to 70°C
Weight	11.2kg

● Hydraulic(measured with P=100bar, VG46, 90l = 40 ±5 °C

Operating Pressure(pilot control valve)	X, P: 25-315 bar Y:<10 bar
Operating Pressure(main valve)	A,B,P:<350bar T(internal drain)<10bar T(external drain)<250bar
Nominal flow (ΔP=10bar)	180L/min
Maximum flow	460L/min
Pilot flow of Port X and Port Y(input signal 0 → 100%, pressure 315 bar)	8.5L/min
Hydraulic fluid	Mineral Oil(HL, HLP) (according to DIN 51 524)
admissible degree of contamination of the hydraulic fluid(pilot control valve)	Maximum admissible degree of contamination of the hydraulic fluid, cleanliness class 7 according to NAS 1638 (c)
admissible degree of contamination of the hydraulic fluid(main valve)	Maximum admissible degree of contamination of the hydraulic fluid, cleanliness class 9 according to NAS 1638 (c)
Hydraulic fluid temperature	10 to 80 °C(preferably +40 to +50°C)
Viscosity Range	20 to 380mm ² /s(preferably 30 to 46mm ² /s)
Hysteresis	≤1%
Response Sensitivity	≤0.5%

● Electrical

Rated current	2.5A
Solenoid coil resistance	Cold value 2.7Ω Maximum hot value 4.05Ω
Actuated time	ED100%
Maximum coil temperature	150°C
Protection class	IP65

● Amplifier

Type	Digital
Supply Voltage	DC24V(19-35V)
Power Consumption	<72VA
Current Consumption	<2A
Command Value	±10V(Re>50KΩ) or 4-20mA(Re<200Ω)
Measuring output Actual Value	±10V(IL<2mA) or 4-20mA(RL<200Ω)
Electrical connection	Connector (according to DIN EN 175201-804)
Protection class	IP65



Electrical Connection

● Connector(According to DIN EN 175201-804)

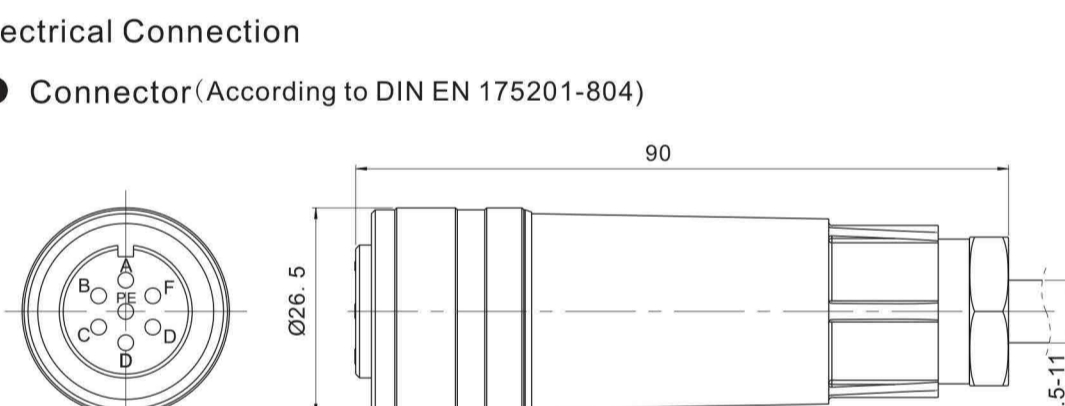

● Pin Assignment

Contact	Function	-A1 voltage type	-F1 Current type
A	Power Supply	DC24V(19-35V)	
B		0V	
D	Differential amplifier input (command value)	±10V(Re>50KΩ)	4-20mA(Re<200Ω)
E		Reference Potential command value	
F	Measuring output (actual value)	±10V(IL<2mA)	4-20mA(RL<200Ω)
C		Reference Potential actual value	
PE	Earthing	Connected to the valve side cover and housing	

Command value:

Positive command value (0...10 V or 12...20 mA) at D and reference potential at E result in flow from P → A and B → T

Negative command value (0...-10 V or 12...-4 mA) at D and reference potential at E result in flow from P → B and A → T

Actual Value:

Actual value 0 ... +10 V (or 12 ... 20 mA) at F and reference potential at C result in flow from P → A and B → T.

Actual value 0 ... -10 V (or 12 ... -4 mA) result in flow from P → B and A → T.

Notice:Electrical signals provided via control electronics (e. g. actual value) must not be used for switching off safety-relevant machine functions.



Connection cable: Recommendation

- Up to 25m cable length type LIYCY 5 x 0.75 mm²
- Up to 50m cable length type LIYCY 5 x 1.0 mm²
- External diameter 6.5 ... 11 mm, Connect shield on PE only on the supply side

● Amplifier Internal Diagram

